

Public Policy and Gender-Based Violence in the Region Tumbes, 2023

Seminario Feijoo, Militza Isabel ¹

Abstract

The purpose of the study was to determine the association between public policy and gender violence, in the Tumbes 2023 region. Women are the main victims of violence exerted within a space of coexistence, perpetrated by the partner or ex-partner, a situation that demand for effective and sustained government actions, which is why both constants will be evaluated.

Methodology: Descriptive-correlational-non-experimental quantitative study, a questionnaire was applied to 39 women victims of gender violence who attended a mental health center in Tumbes (sample), the data collected was subjected to the corresponding descriptive and inferential analysis. through the SPSS version 27 program.

Results: 59% qualified the public policy as moderately effective, for 23.1% it was not very effective, for 7.7% it was not effective at all and for 10.3% effective. The predominant type of violence was psychological at a moderate (51.3%) and severe (30.8%) level. There is no association between the preventive axis ($p= 0.702$) of public policy and gender violence, while the axes of care ($p= 0.006$), protection ($p= 0.036$) and recovery ($p= 0.006$) of public policy had a significant relationship with gender violence.

Conclusion: The alternative hypothesis was accepted and the null hypothesis was rejected, establishing that, if there is a significant association ($p=0.029 < p\text{-value} = 0.01$) between public policy and gender violence, in the Tumbes region 2023.

Keywords: *Public policy, gender violence, intervention plan, prevention, attention, protection and recovery.*

1. Introduction

Gender-based violence, specifically, the mistreatment of women, is considered a public problem, due to the social, health and economic repercussions within a nation, making it imperative that immediate and effective actions be taken by the main political and social operators to counteract it. Constantly evaluating the role of the actions implemented at the national, regional and local levels in the face of gender-based violence will strengthen the promotion of gender equality and improve services for the prevention, care, protection and reintegration of women victims of abuse.

The World Health Organization points out that the mistreatment of women is a pandemic, given the scope and extension of this problem, as it affects 736 million women around the world, having that, for every three women, one of them was a victim of physical and/or sexual aggression, with the main perpetrator being the spouse or ex-spouse. Regarding

¹ Universidad Cesar vallejo – Piura – Perú, miseminarios@ucvvirtual.edu.pe, <http://orcid.org/0000-0002-2584-2648>

victims of sexual assault, she points out that, in many of these cases, the aggressor turns out to be a person other than the family, maintaining that the figures of gender-based violence have remained unchanged and women continue to be the most affected population compared to men (UNFPA, 2021).

Bermúdez & Meléndez (2020), indicate that in the European Union, Oceania and Africa, there are high rates of violence against women, also the European continent has a low prevalence, however, 22% of women who have been in a cohabitation, affirm the suffering of physical and/or sexual aggression at some point in their conjugal union, In addition, 43% suffered psychological violence. Europe, despite being a first-world region, also registers cases of violence against women, although in a very small proportion.

For its part, WHO (2021), carried out an analysis of the prevalence of gender-based violence in 161 countries, inferring that one in three women presented physical and/or sexual aggressions, more than a quarter of women were victims of aggression, figures ranging from 20% in the Western Pacific, 22% in nations with solid economies, 33% for the African region, 31% in the Eastern Mediterranean, 33% in Southeast Asia and 25% in Latin America, without any doubt, this problem is much more settled in developing countries with weak economies, which allocate insufficient resources for the development of sustainable and effective actions against gender-based violence.

The prevalence of gender-based violence in Latin America, Bott et al, (2021), points out that during these last years, these figures varied, from 14% to 17% in the nations of Brazil, Panama and Uruguay, while in the Bolivian Republic it reached 58.5%, the physical and sexual types are the predominant ones, being the spouse or ex-spouse, The main aggressor, with significant peaks of increase in gender-based violence in its physical form also observed in the Dominican Republic. In Latin America, there is a marked variation in the incidence of violence against women from one nation to another, and it will ultimately be up to each government to reduce these rates of mistreatment of women.

In Ecuador, situations of violence against women have remained static for decades, one out of every three days, a femicide was registered, only during the first quarter of 2021, 20 women being murdered by their partner or ex-partner, 70% of them mothers, who left 11 minors orphaned, an interesting fact was that two, of the victims had protection or aid tickets, revealing the shortcomings at the level of the protection system towards victims of gender-based violence, increasing the feeling of normalization of impunity in the Ecuadorian population (ALDEA, 2021).

In Peru, during the year 2020, the National Institute of Statistics and Informatics indicates that out of every 10 women of childbearing age, five of them were victims of abuse, reflecting in an incidence of 54.8%, exercised mostly by the spouse or ex-spouse, 27.1% were victims of physical violence, 50.1% of the psychological type and 6.0% of sexual abuse, 80% of the victims resided in urban areas, only 26.2% asked for help, of this figure 83.9% went to the PNP, 7.8% to the Prosecutor's Office and 6.7% to the MIMP, while 73.8% did not report because they considered it unnecessary, due to shame, lack of knowledge of help services, fear, among other reasons (INEI, 2021).

Now, according to a report called femicides and mistreatment of women during the period 2015 to 2021, it reported a considerable decrease in this problem at the national level, by 16 percentage points between 2013 and 2021, however Madre de Dios, Apurímac, Cusco, Puno and Arequipa, registered an increasing trend of this problem while Loreto and Ucayali presented the lowest values. (INEI, 2022).

In the department of Tumbes, according to a journalistic note in La Republica, (2022), until the first half of that year, 998 complaints of domestic violence and 03 attempted femicides were reported, with 88.1% of the victims of domestic violence being women and only 11.9% men, the physical and psychological type were predominant, 212 cases were presented in the province of Zarumilla, 73 cases were registered in the province of

Contralmirante Villar and 713 cases were registered in Tumbes province, where 359 of these complaints were registered in La Familia police station, 121 in CEM Andrés Araujo Moran, 105 in CEM Corrales, 100 complaints in CEM Pampas de Hospital and 28 in CEM La Cruz police station.

In the border department of Tumbes, a large number of cases of violence against women have been registered, who present some degree of social or economic vulnerability or in a situation of transit, such a problem could be the consequence of behavioral patterns that normalize such violent expressions, finding justification and social acceptance, without a doubt, they are the result of deficient education and ineffectiveness of the main social actors or political decision-makers. Thus, after having developed the analysis of this problem, in the preceding paragraphs, the undersigned proposed the approach to this problem through this thesis, for which the author started from the following statement or question: What is the level of association between public policy and gender violence in the Tumbes Region? 2023?

The thesis argued its social relevance in addressing a public problem, given that gender violence is framed as such, since it mainly affects a large population group, violating their human rights and negatively impacts a certain commune in a personal, family, social and institutional way, demanding coherent actions that seek to eliminate all violent expression. Mainly targeting women and vulnerable groups, the study was aligned with the fifth Sustainable Development Goal.

The theoretical contribution of the study was based on the information collected, consulted, analyzed, synthesized and debated, which could be compared with the cognitive gap and the already existing theories on the role or performance of local governments in the face of gender-based violence, as well as could incorporate new information contextualized in a certain region.

The practical usefulness is basically based on the results and the intervention proposal developed by the author, which are available to the competent authorities to improve or, failing that, sustain the different actions against gender violence, taking into account that the process of modernization of the state obliges public institutions to constantly evaluate their services. in such a way that continuous improvement is achieved within public institutions.

And finally, the methodology, technique and instrument used during the data collection process, as they enjoy reliability and respective validity, can be useful for future research on the subject matter, as well as the results and conclusions can be contrasted and discussed for similar studies.

In this way, for the development of the research, the general objective was to determine the association between public policy and gender-based violence, Tumbes 2023.

However, the following specific objectives were also proposed: First objective, to determine the level of effectiveness of public policy in the Tumbes 2023 region. Second objective, to determine the types of gender-based violence according to the level of severity predominant in the Tumbes 2023 region. Third objective, To determine the association between the preventive axis of public policy and gender-based violence, Tumbes 2023. Fourth Objective, to determine the association between the focus of public policy and gender-based violence, Tumbes 2023. Fifth objective, determine association between the public policy protection axis and gender-based violence, Tumbes 2023, Sixth objective, determine association between the public policy recovery axis and gender-based violence, Tumbes 2023.

2. Objectives

2.1 General objective

Determining the association between public policy and gender-based violence, Tumbes 2023.

2.2 Specific objectives

- Determine the level of effectiveness of public policy in the Tumbes 2023 region.
- To know the types of gender-based violence according to the level of severity predominant in the Tumbes region 2023
- Determining the association between the preventive axis of public policy and gender-based violence, Tumbes 2023
- Determining the Association Between the Public Policy Focus and Gender-Based Violence, Tumbes 2023
- Determining the association between the protection axis of public policy and gender-based violence, Tumbes 2023
- Determine association between the recovery axis of public policy and gender-based violence, Tumbes 2023.

3. Methodology

3.1 Type and design of research

The study developed had a quantitative methodological approach, according to Gallardo (2017), this paradigm seeks to verify the hypotheses raised, resorting to empirical observation and experimentation in samples of a wide scope, in order to verify and perfect the existing laws.

Quantitative research uses visible methodology, in addition to specifically using the technique, strategy and instrument in order to assess, quantify, weigh, among others, in the most objective way possible, a certain contextual aspect, quantity is framed as a key unit to analyze, which is why it is called quantitative. (Vargas, 2011)

For his part, Hernandez; Fernandez & Baptista (2014) point out that quantitative research collects information to test hypotheses, whose basis for measurement is numerical, in addition to analyzing the information or data collected statistically, in order to establish behavioral patterns and verify postulates.

The type of study was descriptive - correlational, since only the frequency and characteristics of a certain event were described and explained, which was subjected to a previous analysis, in other words, the researcher was only subjected to collecting and analyzing the data of the constants object of research and their behavior within a certain population. Correlational, since the purpose of the study was to assess some type of association between the constants under investigation. (Garcimartín, 2016). The study had a non-experimental methodological design, this type of studies are carried out without the need for the deliberate manipulation of the constants object of study, that is, there was no intentional manipulation of variables, basically limiting itself to the observation of behavior within its natural environment, for its consequent analysis. (Hernandez; Fernandez & Baptista, 2014)

Kerlinger (1979) points out that this study design is any research in which the manipulation of variables is made impossible or random assignment to individuals or conditions is impossible (p.116). In this sense, the following diagram was assigned to the research:

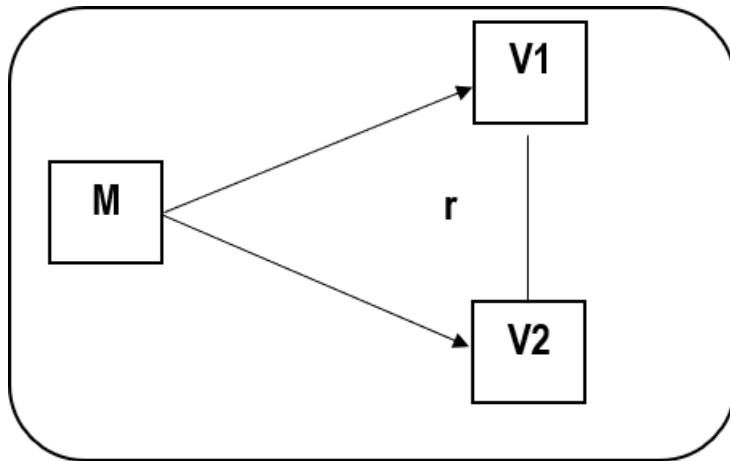

Where:

M : Women victims of violence treated at the Mental Health Centre Virgen del Cisne Community – Tumbes 2023.

V1 : Constant 1 – Public Policy

V2 : Constant 2 – Gender-based violence

r :Relation

3.2 Sampling, sampling, inclusion and exclusion criteria

Sample

Subset of the population that is the subject of observation, with whom the collection of information is developed, having to define it in addition to delimiting it in advance for greater precision, this population proportion will undoubtedly represent the population. (Hernandez, R; Fernandez, C & Baptista, 2014, p. 173).

In this sense, the representative sample of the study was made up of all those women of childbearing age with a diagnosis of violence attended at the Virgen Del Cisne community health center - Tumbes district, during the first half of 2023.

Sampling

For the research, convenience sampling was used, according to Gallardo (2017), it is a type of non-probability sampling, for which each of the participants will be selected in a convenient way.

Inclusion criteria

Women of legal age.

Women in cohabitation or ex-cohabitation

Exclusion Criteria

Women with some degree of mental disability, which makes it impossible to fill out the instruments.

Single women, with no history of marital relations.

Women who do not provide availability to participate.

3.3 Data collection techniques and instruments.

Casas (2003) argues that the survey is the action of grouping structured study processes or procedures through which different data will be collected and analyzed from a

respective sample belonging to a universe, from which a series of particularities were explored, described, and explained (pp. 527-538).

A questionnaire was used as an instrument, with 24 questions, structured according to dimensions of each variable, this instrument included 02 sections, each of the sections of the questionnaire had 12 questions with closed answers.

In the first section, the effectiveness of public policy was assessed, contemplating 12 questions with closed answers, whose rating scale used was Likert type: (0) Never, (1) Sometimes, (2) Almost always, (3) Always. In such a way, at the end of the completion of the questionnaire, a maximum score of 36 points will be obtained and a minimum score of 0 points, failing which, the public policy variable could be assessed as:

Effective	(25 to 36 points)
Moderately Effective	(13 to 24 points)
Not very effective	(1 to 12 points)
Not effective	(Score equal to zero)

As for the questionnaire to assess gender-based violence, it comprises three possible alternatives, for which a Likert-type rating scale will be used (1) never (2) sometimes, (3) Always, at the end of the correct completion of the questionnaire, this instrument obtained a maximum score of 36 points and a minimum score of 12 points, valuing gender-based violence as:

Slight	(1 – 12 points).
Moderate	(13 – 24 points)
Severe	(25 – 36 points)

Validation

For the validation of the instrument, it was submitted to the analysis of expert judgment, for which 3 highly qualified professionals in the subject to be studied were summoned, who indicated that the items are coherent with the objectives set.

Reliability

Once the content of the questionnaires was validated, a pilot test was carried out on a group of people (10 maximum) with qualities similar to the population under study.

The data obtained were analyzed, which were finally subjected to a Cronbach's alpha reliability test, where the questionnaire to assess public policies obtained 0.73313 and 0.78861 for the instrument to measure the variable gender violence, both results determine an excellent level of reliability.

4. Results

Preventive axis of public policy against gender-based violence.

Question 1	Answers	Fi	%
Do you think that, in the District of Tumbes, investment projects, work plans, ordinances or laws are being developed to prevent and/or eradicate gender-based violence?	No	16	41.0
	Sometimes	15	38.5
	Almost always	4	10.3
	Always	4	10.3
	Total	39	100.0

Question 2	Answers	Fi	%
Do you think that there is a joint effort between the municipality, the women's emergency center, the PNP, the justice of the peace, the health center and the general population to prevent gender-based violence?	No	15	38.5
	Sometimes	12	30.8
	Almost always	7	17.9
	Always	5	12.8
	Total	39	100.0
Question 3	Answers	Fi	%
Have you received information (campaigns, talks, trainings, workshops and/or visits) regarding the prevention, punishment and/or eradication of violence against women and other members of the family group?	No	10	25.6
	Sometimes	15	38.5
	Almost always	8	20.5
	Always	6	15.4
	Total	39	100.0

Table 1: Numerical and percentage distribution of the answers obtained for the questions, which determined the level of effectiveness of the preventive axis of public policy.

Note: Questionnaire to measure public policy and gender-based violence - Tumbes 2023

Interpretation: Table and graph 1 show the answers to the questions asked to the victims of gender violence, who in 41.0% indicated that in the District of Tumbes they are not developing investment projects, work plans, ordinances or laws to counteract the VDG, also 38.5% of the interviewees indicated that there is no evidence of an articulated work between the main operators and 38.5% sometimes received information through actions promotional preventive activities such as talks, campaigns, trainings, workshops or others.

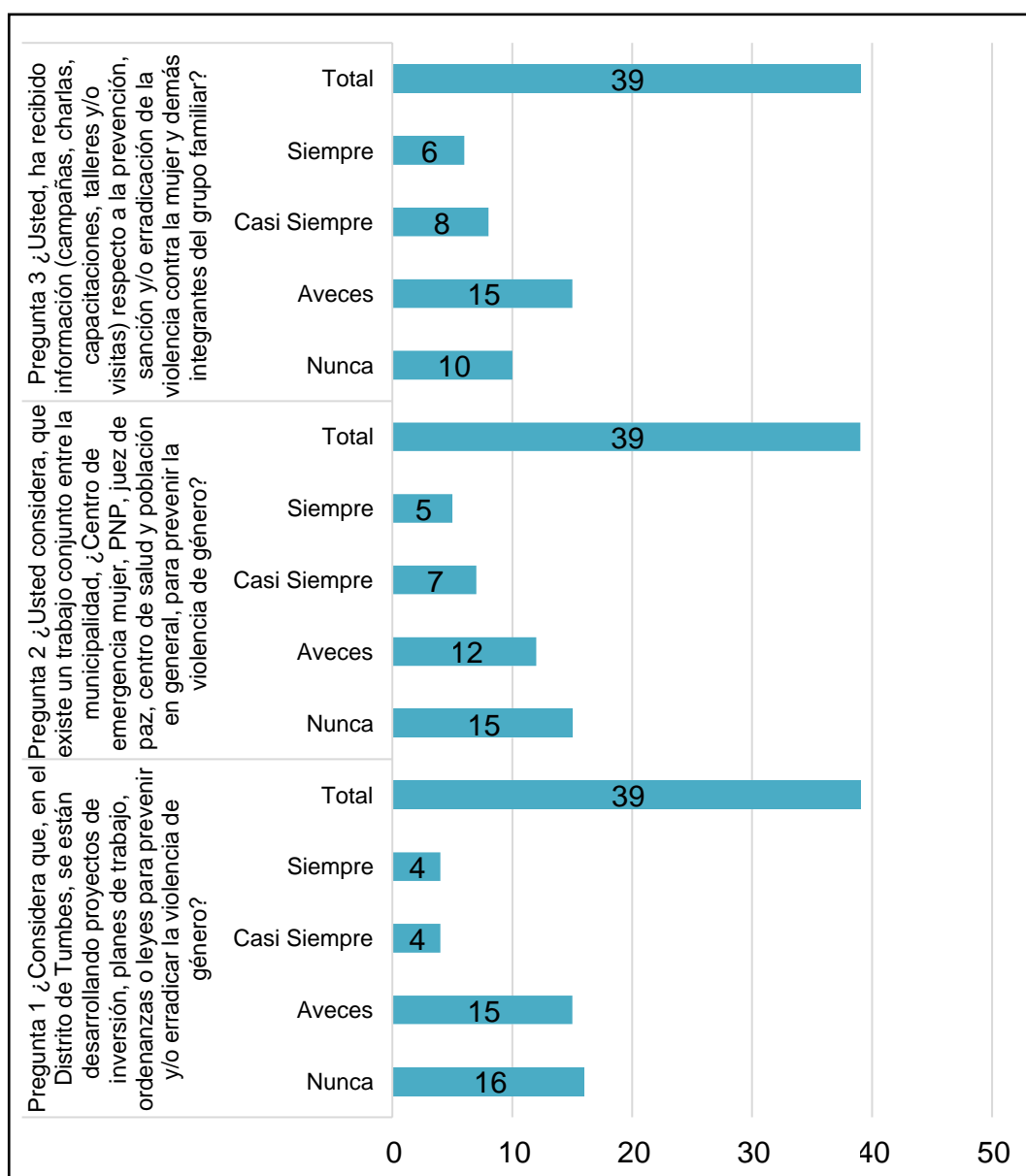

Figure 1: Graphical representation of the answers obtained for the questions, which determined the level of effectiveness of the preventive axis of public policy.

Focus on public policy in the face of gender-based violence.

Question 4	Answers	Fi	%
Do you consider that the action of the police authority in the face of a complaint of violence against women is taken diligently and without prejudice towards the victim?	No	13	33.3
	Sometimes	16	41.0
	Almost always	6	15.4
	Always	4	10.3
	Total	39	100.0
Question 5	Answers	Fi	%
Do you believe that the health sector has the necessary and competent professionals to provide quality care to victims of	Sometimes	14	35.9
	Almost always	12	30.8

violence?	Always	13	33.3
	Total	39	100.0
Question 6	Answers	Fi	%
	No	13	33.3
	Sometimes	15	38.5
Do you think that the women's emergency center in your jurisdiction immediately attends to the victim?	Almost always	3	7.7
	Always	8	20.5
	Total	39	100.0

Table 2: Numerical and percentage distribution of the answers obtained for the questions, which determined the level of effectiveness of the focus of public policy.

Note: Questionnaire to measure public policy and gender-based violence - Tumbes 2023.

Interpretation: Table and graph 2 involve questions to determine the level of effectiveness of public policy against gender violence in Tumbes, obtaining that 41.0% consider that sometimes the police attend diligently and without prejudice to complaints about GBV, 35.9% consider that the health sector only sometimes has competent and necessary professionals to provide care and psychological support to victims of GBV. And 38.5% considered that sometimes the CEM of their jurisdiction attends immediately.

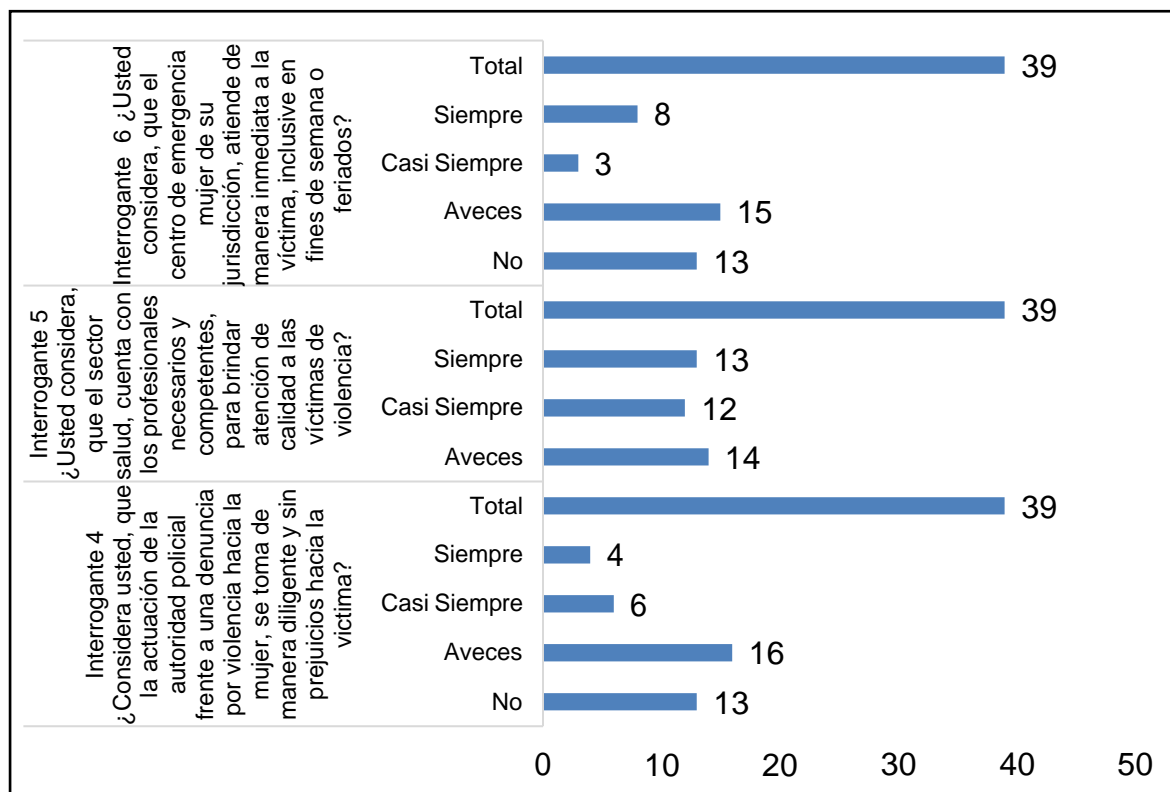

Figure 2: Graphical representation of the answers obtained for the questions, which determined the level of effectiveness of the focus of public policy.

Axis protection of public policy against gender-based violence.

Question 7	Answers	Fi	%
Have you been informed of the existence of a shelter or shelter house to house women victims of violence?	No	16	41.0
	Sometimes	11	28.2
	Almost always	3	7.7
	Always	9	23.1
	Total	39	100.0
Question 8	Answers	Fi	%
Do you consider that protection measures for victims of gender-based violence are provided periodically and timely by the police authority?	No	9	23.1
	Sometimes	18	46.2
	Almost always	6	15.4
	Always	6	15.4
	Total	39	100.0
Question 9	Answers	Fi	%
Do you think that the CEM, the judiciary and the prosecutor's office in your jurisdiction act quickly and guarantee timely protection for women victims of violence?	No	2	5.1
	Sometimes	13	33.3
	Almost always	10	25.6
	Always	14	35.9
	Total	39	100.0

Table 3: Numerical and percentage distribution of the answers obtained for the questions, which determined the level of effectiveness of the protection axis of public policy.

Interpretation: Table and graph 3 analyze the responses provided by victims of violence who went to the Virgen del Cisne mental health center, finding 41% who are unaware of the existence of a shelter or shelter for women survivors of gender violence, 46.2% believe that only sometimes the police authority provides protection measures in a periodic and timely manner. In addition, 35.9% consider that the CEM, the Judiciary and the Prosecutor's Office conduct their processes quickly, thus guaranteeing the protection of victims of VDG.

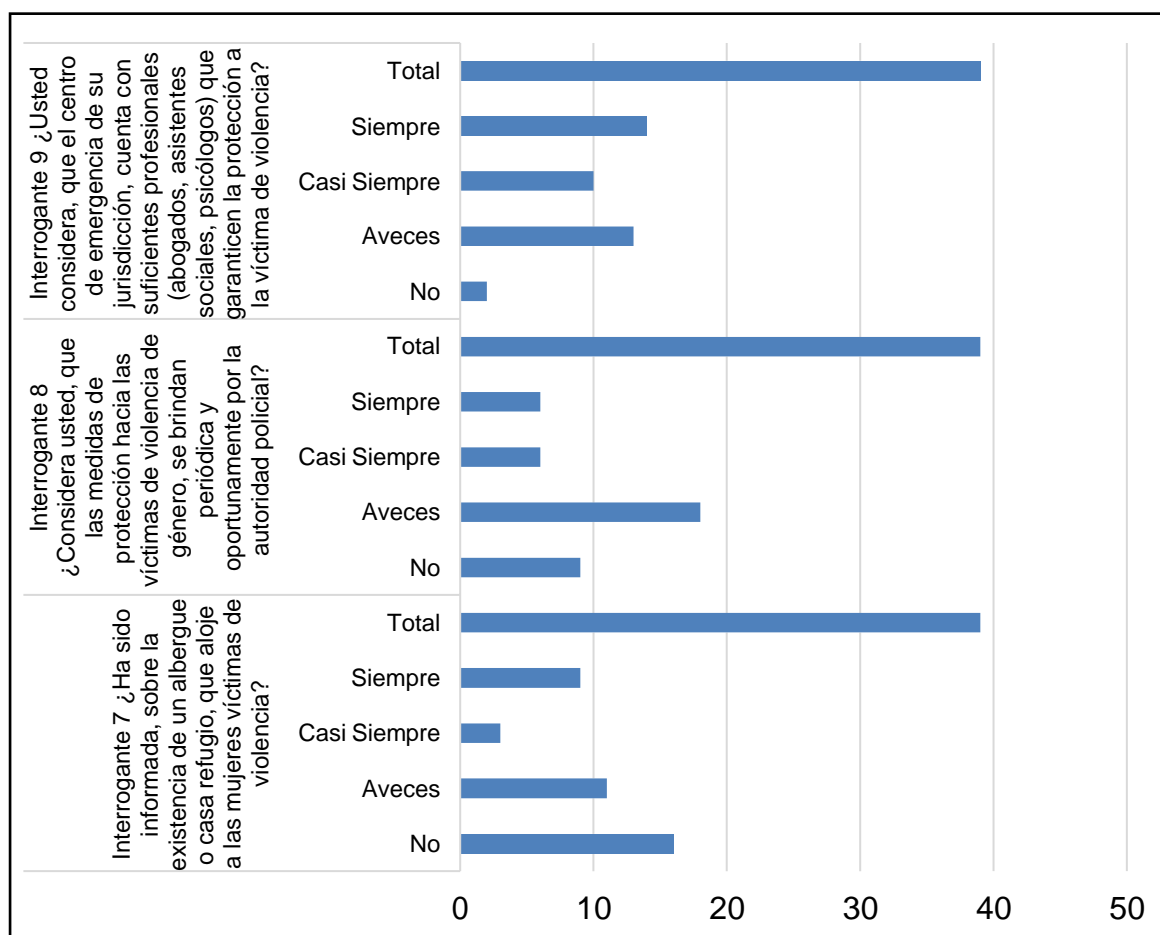

Figure 3: Graphical representation of the answers obtained for the questions, which determined the level of effectiveness of the protection axis of public policy.

Axis: recovery of public policy against gender-based violence.

Question 10	Answers	Fi	%
Do you think that the regional and local government are developing actions that seek to strengthen the economic independence and employability of women survivors of gender-based violence?	No	8	20.5
	Sometimes	16	41.0
	Almost always	9	23.1
	Always	6	15.4
	Total	39	100.0
Question 11	Answers	Fi	%
Do you think that the health professionals of the IPRESS district are prepared to guarantee adequate emotional support for women survivors of gender-based violence?	No	1	2.6
	Sometimes	15	38.5
	Almost always	16	41.0
	Always	7	17.9
	Total	39	100.0
Question 12	Answers	Fi	%
Do you think that there is an articulated work between the	No	6	15.4

CEM, PNP, IPRESS and local government, to generate spaces or better conditions for women survivors of gender violence?	Sometimes	14	35.9
	Almost always	12	30.8
	Always	7	17.9
	Total	39	100.0

Table 4: Numerical and percentage distribution of the answers obtained for the questions, which determined the level of effectiveness of the public policy recovery axis.

Interpretation: Table and graph 4 analyzed the axis of recovery of public policy in the face of VDG in Tumbes, so much so that 41% indicated that sometimes the regional and local government develops actions to strengthen the economic independence and level of employability of women survivors of VDG, in addition 41% refer that the IPRESS of their jurisdiction almost always has professionals prepared for emotional support and 35.9% believe that the CEM, PNP, IPRESS and the local government promote spaces to improve conditions for women survivors of VDG.

5. Discussion

This research addressed public policy and gender-based violence in the Tumbes 2023 region as the main problem. Taking into consideration the definition of public policy, developed by Fernandez (2017) who in his article cites Arroyave (2011, p. 96) defining them as government interventions, to respond to a public problem present in society. They are also understood as the grouping of elements through which the government, after having identified a need or problem (economic, political, environmental, social, cultural, etc.), implements a set of interventions, proposed with the participation of the affected population group. In this sense, the results obtained in the study will be analysed accordingly:

First specific objective: To determine the effectiveness of public policy against gender-based violence, in Tumbes 2023.

After the respective data analysis, it was determined that 59% of women victims of gender-based violence rated the public policy as moderately effective, 23.1% considered it not very effective, 7.7% not at all effective and only 10.3% considered it effective. In this regard, Ferro (2023) in his study on public policies and gender-based violence in the Cuzco region, managed to determine that 52.1% rated the public gender policy as regular, 33.6% considered them optimal and only 14.4% inferred that they were deficient policies, observing that, although there is agreement that most of the interviewees indicated that they were regular, There is a considerable percentage in this region that qualifies them as optimal, this last data differs or is contradictory to that found in this research.

For his part, Purizaga, (2021) in his study, on public policy and gender-based violence in a populated center of Porvenir Trujillo, indicated that 36% of victims of violence perceived government actions as inadequate, these results do not coincide with those found in this research.

Coincidentally, Saavedra (2021) carried out an analysis of the actions developed in the Lambayeque region to address violence against women, indicating that women's emergency centers, installation of rural strategies, as well as the creation of a regional consultation space called the instance of concertation in the Lambayeque region have been implemented.

Another contribution of the study was to assess the level of effectiveness by axes of intervention of public policy against gender violence, obtaining that 43.60% rated the public policy as moderately effective in the prevention axis, 46.2% indicated that it is not

very effective and 35.9% qualified it as moderately effective in terms of the attention axis. while the protection axis, the majority of the victims of GBV (46.2%) rated it as not very effective and finally the recovery axis for 48.7% as moderately effective, it stands out that the preventive axis shows a high level of dissatisfaction of the victims, since despite the actions developed in the department of Tumbes, The population considers these government actions to be moderately effective.

On this, Lewington et al., (2022), conclude that there are feasible policy alternatives, including a verticality perspective, so that sufficient resources are allocated, at the national or local level to strengthen the educational level of girls, with a comprehensive community approach in a horizontal way, which seeks to generate skills and knowledge, whose sole purpose is to empower young women in Uganda.

Ibarra (2020), on the other hand, maintains a similar position, indicating that the policies developed in the Peruvian state are not effective at all, due to a number of elements that influence the application of existing standards, such as the deficient human potential that brings together technical and attitudinal competencies both in the field of public administration and jurisdiction. affecting the main victims of VDG, in addition to interfering with the correct and timely monitoring of the protection measures that have been granted to these women.

For his part, Infante (2023) states that the effectiveness of these measures during the COVID-19 health emergency were not fully guaranteed the protection of women victims of psychological and physical abuse, even pointing out that the legal instruments issued by the judiciary should be supported by precautionary measures.

Finally, regarding the analysis of public policy against domestic violence, Rengifo Arias et al., (2019) indicate that it is indisputable that the Colombian government is paying special attention to this public problem, with a growing trend, however these designed and implemented actions have different elements or characteristics that make them ineffective, given that this phenomenon of violence involves vertebral aspects and multivariate solutions at the level of the structure family and community. The authors also point out that it is important for the government to promote a sincere debate regarding the effectiveness of the criminalization and punishment of domestic violence, given that the figures remain high.

Second specific objective: To know the types of gender-based violence according to the level of severity predominant in Tumbes 2023,

The data show that 100% of the women participating in the study suffered psychological violence from their partner or ex-partner, with 51.3% suffering psychological violence at a moderate level, 30.8% severe and 17.9% at a mild level, in second place, physical violence was located in 97.4% of the victims. in its moderate (43.6%), mild (30.8%) and severe (23.1%) severity levels, in addition to economic violence in third place in 92.3% and finally sexual violence was located in 76.9% of the total of women victims of VDG, who attended the Virgen del Cisne – Tumbes 2023 community mental health center, It should be noted that many of the interviewees have suffered more than one type of violence simultaneously, which generally increases the level of severity of GBV in the interviewees.

Data contradictory to those shown by Borràs, B; Mondon, J; Monroy, D; Romaguera (2023) in her research on the detection of gender-based violence in women who attended a health institution in Barcelona – Spain, who found that 70.9% presented gender-based violence, when making the distribution by types, found that most of the interviewees referred psychological violence first, followed by the physical and sexual type later. Likewise, Saavedra (2021) found that physical violence affected 58% of his sample, 52% almost always suffered psychological violence, a similar figure also presented sexual violence and 78% had experienced economic violence, ranking as the most predominant

type in the Lambayeque Region and in the same line, Ferro (2023) found that 56.2% were victims of violence against women at a medium level of severity, It also indicates that 54.1% presented psychological violence, 52.7% of sexual type, ending by indicating that it was the type of physical violence that was predominant in the study group.

The aforementioned researchers obtained different results regarding the type of gender-based violence predominant in their study populations, but it is agreed that psychological, physical, sexual and economic types continue to be the common forms of mistreatment of women.

Moreira & Zambrano (2023) in their article, concludes that the most common forms of violence were psychological, physical and sexual, in the province of Manabí, they also remark that the incidence of gender violence against women has a growing behavior, for a number of reasons, despite this the justice system is not very diligent, In the context of a series of elements that are detrimental to the victim, the author also states that the province of Manabí has deficiencies in the implementation of public policies and regulations vis-à-vis the VDG.

Third specific objective: To determine the association between the preventive axis of public policy and gender-based violence in Tumbes 2023.

Both constants were subjected to Spearman's Rho correlation test, obtaining a significance level equal to 0.702; being greater than $p\text{-value} = 0.01$, in such a way that the null hypothesis is accepted and the alternative hypothesis is rejected, stating that there is no significant association between the preventive axis of public policy and gender-based violence, Tumbes 2023. Likewise, when observing the behavior of both constants through descriptive analysis, it is inferred that the majority of victims of gender-based violence rated the preventive axis of public policy as moderately effective (43.6%) and not very effective (38.5%), most of whom suffered gender-based violence at a moderate level.

Demanding greater preventive and promotional interventions on the part of the competent institutions, these actions must have a communication strategy with a social impact, which not only promotes emergency or complaint lines, but also serves as a platform to re-educate in terms of gender roles, stereotypes, customs, etc., historically established, which lead to the adoption of extremist positions.

Along these lines, Bolarinwa et al., (2022), argue that those responsible for the development of public policies should focus their attention on improving and/or strengthening the bottlenecks against the prevention of spousal violence in that nation, arguing that there is a need to empower women in the fight against gender-based violence.

Fourth Specific Objective: To determine the association between the focus of public policy and gender-based violence, Tumbes 2023.

When the frequency distribution between these variables was carried out, it was obtained that those women victims of gender violence at moderate and severe levels rated the attention axis as not very effective (46.2%), while a minimum of victims of GBV at mild and moderate levels rated this axis as effective (17.9%), however, when these variables were subjected to the Spearman rank correlation coefficient, A $p\text{-value} = 0.006$ was obtained $< \text{tabular } p = 0.01$ whose correlation coefficient was -0.430 , which allows us to accept the alternative hypothesis and reject the null one, in this sense it is stated that if there is a moderate inverse correlation between the focus of public policy and gender violence, a result that is consequential, with that of the author Guerra (2023), who with respect to police attention to gender-based violence concludes that there is an incidence of Public Policies and the exercise of the police function on violence against women in the Sicuani police stations, with a level of significance of 0.00.

Also, Vilca (2022), refers to the process of attention in cases of VDG, that many of the assaulted women who come to make their complaint, end up dismissing it, due to the exhaustion of the process itself, he also points out that the first contact or the first attention would significantly influence to continue with the complaint process, finding marked deficiencies in the process of implementation of public policy, Highlighting the deficient intervention during the recovery of the aggressor, the deficient technical-operational capacity to implement measures to protect the victim, it even points out that preventive promotional measures against violence must be deepened and reinforced.

Fifth specific objective: Determine association between the protection axis of public policy and gender-based violence, Tumbes 2023.

The frequency distribution between these variables was carried out and it was obtained that those women victims of gender violence at mild, moderate and severe levels rated the attention axis as not very effective (46.2%), while a minimum of victims of VDG at mild and moderate levels rated this axis as effective (23.1%), however, when these variables were subjected to the Spearman rank correlation coefficient, A p-value = 0.036 was obtained, < tabular p = 0.01 whose correlation coefficient was -.336, understanding that the alternative hypothesis is accepted and the null hypothesis is rejected, in this sense it is affirmed that there is an average negative correlation between the protection axis of public policy and gender violence.

Coincidentally, Alva (2022) in his research on the influence of protection measures in situations of domestic violence concludes that there is an inverse association between these constants, where it is reflected that protective measures influence the reduction of the degree of moderate violence ($.09 \leq R^2 < .25$), so he affirms that protection interventions are significantly associated with gender-based violence.

Sixth Specific Objective: Determine the association between the recovery axis of public policy and gender-based violence, Tumbes 2023.

When applying the correlation test, it was obtained that the p-value is equal to 0.032, which is a result lower than p-value = 0.05, in that sense it is established that there is a significant association between the axis recovery of public policy and gender violence, Tumbes 2023, establishing a correlation coefficient -.344 being an indirect and considerable relationship. In this sense, it can be stated with 95% confidence that there is a negative – considerable association between the recovery of public policy axis and gender-based violence, Tumbes 2023.

These associations generally reflect the need to continuously and methodically evaluate the services offered to victims of GBV, which must be free, timely, accessible, comprehensive and sustainable, taking into account that these services provided correctly reduce the degree of severity of gender-based violence in Tumbes 2023. The aspects involved during the preventive, care, protection and recovery service of the victim cover a number of aspects that address from infrastructure, equipment, availability of human potential, truly available helplines, spaces for the recovery and reintegration of the victim, as well as the availability of resources for the execution of strategic interventions against gender violence.

Finally, through the study, there is sufficient evidence to reject the null hypothesis and accept the alternative hypothesis, establishing that there is a significant association ($p = 0.029 < p = 0.01$) between public policy and gender-based violence, Tumbes 2023.

The data are similar to those obtained by Purizaga (2021), who was also able to conclude the existence of a negative association between public policies and violence against women of victims of abuse in the Alto Trujillo population center of the district of El Porvenir 2020.

Ferro (2023), also in her research, concluded that public gender policies significantly influence violence against women in the Cusco Region by 2022.

6. Conclusions

1. It was established that there is a significant association ($p = 0.029 < p = 0.01$) between public policy and gender-based violence, Tumbes 2023.
2. The effectiveness of public policy against gender-based violence was rated as moderately effective by 59% of women victims of gender-based violence, 23.1% thought it was not very effective, 10.3% was effective and 7.7% rated it as not at all effective.
3. The predominant type of gender-based violence in the participants was psychological, since it occurred in 100%, where 51.3%, 30.8% and 17.9% respectively, registered moderate, severe and mild levels, respectively.
4. It was determined that there is no significant association between the preventive axis of public policy and gender-based violence, Tumbes 2023 ($p = 0.702, > p\text{-value } 0.01$), so the null hypothesis is accepted and the alternative hypothesis is rejected.
5. If there is a negative-considerable association between the focus of public policy and gender-based violence, Tumbes 2023, because the calculated p-value was 0.006, which is a result lower than $p\text{-value} = 0.01$, so the researcher's hypothesis is accepted and the null hypothesis is rejected.
6. If there is a negative – considerable association between the protection axis of public policy and gender-based violence, Tumbes 2023, because the calculated p-value was 0.036, which is a result lower than $p\text{-value} = 0.01$, so the alternative hypothesis is accepted and the null hypothesis is rejected.
7. It is stated that there is an association ($p=0.006$) between the axis recovery of public policy and gender-based violence, Tumbes 2023, so the researcher's hypothesis is accepted and the null hypothesis is rejected.

7. Recommendations

1. Studies such as the one developed should be replicated and expanded, which allow at the macro level throughout the Tumbes Region, to make a diagnosis from the perception of women victims of violence, to assess preventive, care, protection and recovery actions against gender violence, so that the actions of the axes identified as bottlenecks or ineffective can be re-empowered or, failing that, improved.
2. Local bodies for consultation on violence against women and members of the family group must be operational and active, since it is from these spaces in which the main authorities participate that follow-up actions can be implemented in preventive services, care, protection and recovery of victims.
3. The regional government of Tumbes must lead preventive promotional actions against gender-based violence, as well as promote the updating and sincerity of local statistics regarding this problem.
4. Each local government must implement budgeted interventions to strengthen inter-institutional management against gender-based violence, as well as ensure that the main operators are prepared in the attitudinal, cognitive and technical operational areas.
5. More studies such as this should be carried out in order to expand the results obtained, considering the constants studied here.

References

- VILLAGE. (2021). 20 femicides in Ecuador since the beginning of the violence. 20–24.
- Alva, L. (2022). Influence of protection measures in cases of family violence in a family court in Peru 2020-2021.
- Bermúdez, M. P., & Meléndez-Domínguez, M. (2020). Epidemiological analysis of gender-based violence in the European Union. *Annals of Psychology*, 36(3), 380–385. <https://revistas.um.es/analesps/article/view/428611/286811>
- Bolarinwa, O. A., Ahinkorah, B. O., Frimpong, J. B., Seidu, A.-A., & Tessema, Z. T. (2022). Spatial distribution and predictors of intimate partner violence among women in Nigeria. *BMC Women's Health*, 22(1). <https://doi.org/10.1186/s12905-022-01823-w>
- Borràs, B; Mondon, J; Monroy, D; Romaguera, A. (2023). Gender-based violence detection in young women attending a primary healthcare center. In *Primary Care* (Vol. 55, Issue 1). <https://doi.org/10.1016/j.aprim.2022.102524>
- Bott, S., Guedes, A., Ruiz-Celis, A. P., & Mendoza, J. A. (2021). Intimate partner violence in the Americas: a systematic review and reanalysis of national prevalence estimates*. 45. <https://doi.org/10.26633/RPSP.2021.34>
- CEPLAN. (2018). National Policy Guide.
- Ombudsman's Office. (2020). Balance on public policy against violence against women in Peru (2015-2020). In *Series of Ombudsman Reports* (Vol. 186).
- Duran, L. (2019). Analysis of gender-based violence and public policies. *Verses* 5–10.
- Fernandez, G. (2017). Social Public Policies: Notes and Reflections. *Revista Cubana de Información y Comunicación*, 13(3), 1576–1580.
- Ferro, A. (2023). Public Gender Policies on Violence against Women in the Cusco Region, 2022. In *Universidad César Vallejo*.
- Furlong, W. (2022). Public policy model with a comprehensive approach to address sexual violence in students at UGEL Sullana. In *Universidad César Vallejo*. <https://hdl.handle.net/20.500.12692/76522>
- Gallardo, E. (2017). Research Methodology. *Continental University*, 1, 98. https://repositorio.continental.edu.pe/bitstream/20.500.12394/4278/1/DO_UC_EG_MAI_UC_0584_2018.pdf
- Garcimartín, P. (2016). Nursing and Qualitative Research: Evidence in Care. *Cardiology Nursing*, 23(69), 23–29.
- Guerra, I. (2023). Public Policies, Exercise of the Police Function in Violence against Women in Sicuani Police Stations, 2022. In *Universidad César Vallejo*. <https://hdl.handle.net/20.500.12692/76522>
- Hernandez, R; Fernandez, C & Baptista, M. (2014). RESEARCH METHODOLOGY. <https://www.ptonline.com/articles/how-to-get-better-mfi-results>
- Ibarra, M. (2020). Public policies in the fight against violence against women as a means of prevention in the Peruvian State. In *UCV*. <https://repositorio.ucv.edu.pe/handle/20.500.12692/42469>
- INEI. (2021). Femicide and violence against women 2015-2020. In *Inter-institutional Statistical Committee on Crime -CEIC*. https://www.inei.gob.pe/media/MenuRecursivo/publicaciones_digitales/Est/Lib1831/libro.pdf
- INEI. (2022). Peru: Femicide and Violence against Women 2015-2021.
- Infante, Jenifer. (2023). Effectiveness of protection measures against violence against women in times of pandemic. *Window 2022*. In *Universidad César Vallejo*.

- The Republic. (2022, July 30). Tumbes registers more than 900 complaints of violence and 3 cases of attempted femicide. 1–9. <https://larepublica.pe/sociedad/2022/07/30/tumbes-registra-mas-de-900-denuncias-de-violencia-y-3-casos-de-tentativa-de-feminicidio-lrnd/>
- Lewington, J., Geddes, R., & Gabagaya, G. (2022). Female empowerment to improve sexual and reproductive health outcomes and prevent violence in adolescent girls and young women in Uganda: evidence reviews for policy. *African Health Sciences*, 22(4), 413–427. <https://doi.org/10.4314/ahs.v22i4.47>
- MIMP. (2016). Supreme Decree approving the National Plan against Trafficking in Persons 2017-2021. In *Diario oficial El Peruano* (pp. 27–93). <https://busquedas.elperuano.pe/normaslegales/decreto-supremo-que-aprueba-el-plan-nacional-contrala-trata-decreto-supremo-n-017-2017-in-1530366-1/>
- Moreira, A & Zambrano, Z. (2023). Types of recurrent gender-based violence in Manabí in 2021, statistical data from OVIGEMA. Verses 1–13.
- WHO. (2021). Violence against women. 139–152. <https://doi.org/10.18356/01f12968-es>
- Purizaga, T. (2021). Public policies and their relationship with violence against women in the town of Alto Trujillo, El Porvenir 2020. In *Universidad César Vallejo*. <https://hdl.handle.net/20.500.12692/76522>
- Rengifo Arias, C. G., Carmona Otálvaro, J. G., & Baena Vallejo, G. A. (2019). Analysis of Public Policies on Domestic Violence in Colombia: An Approach According to the Function and Meaning of the Violent Phenomenon within the Family. *Interdisciplinary: Journal of Psychology and Allied Sciences*, 36(2), 1–12. <https://doi.org/10.16888/interd.2019.36.2.7>
- Saavedra, B. (2021). Intervention Model to Prevent Violence against Women in the Lambayeque Region.
- Torres, J. (2013). Introduction to public policies, concepts and tools from the relationship between the State and citizens. In *IEMP Ediciones*. <http://bit.ly/34siOO5>
- Úbeda, S. (2022). THE ACTIVE PROTECTION OF THE NATIONAL POLICE IN THE FACE OF GENDER-BASED VIOLENCE.
- UNFPA. (2021). Gender-Based Violence: Eradicating Gender-Based Violence and Harmful Practices Against Women and Girls: Transformative Outcomes to Ending Gender-Based Violence Our Programs. 2021.
- Valencia, P., & Nateras, M. (2019). Violence against women as discrimination in contexts of criminal violence: the case of femicide in Medellín and the State of Mexico. *Journal of Criminology*, 62(1), 59–85. <http://www.scielo.org.co/pdf/crim/v62n1/1794-3108-crim-62-01-00059.pdf>
- Vargas Arebalo, C. (2007). Public Policy Analysis. *Perspectives*, 19, 127–136. <http://www.redalyc.org/articulo.oa?id=425942453011>
- Vargas, X. (2011). How to do qualitative research? Vol. <http://www.paginaspersonales.unam.mx/files/981/94805617-Xavier-Vargas-B-COMO-HACER-INVESTIGA.pdf>
- Vera, L. (2020). Gender Focus, Gender-Based Violence and Public Policies: An Approach from the Social Sciences to the Ecuadorian Legal Framework. *Refuse*, 21(1), 1–9. <https://doi.org/10.5281/zenodo.6795951>
- Vilca, J. (2022). Public Policies on Gender-Based Violence, Lima - 2021. In *Universidad César Vallejo*.